

POWERBLOCK

WORLD'S BEST DUMBBELL

PRO Commercial

Commercial Pro 32

In 1993 PowerBlock introduced the world's first quick-change adjustable dumbbell. Today we remain the only adjustable dumbbell found in the training facilities of pro sports teams, major colleges and universities and elite training facilities around the world.

Compact Just 12" in Length at 32 lbs

Convenient Replaces up to 8 pairs of traditional dumbbells

Quick and Easy Adjustability Ideal for supersets and pyramid loading

Trusted by professional & elite athletes and their trainers

Proven performance and reliability

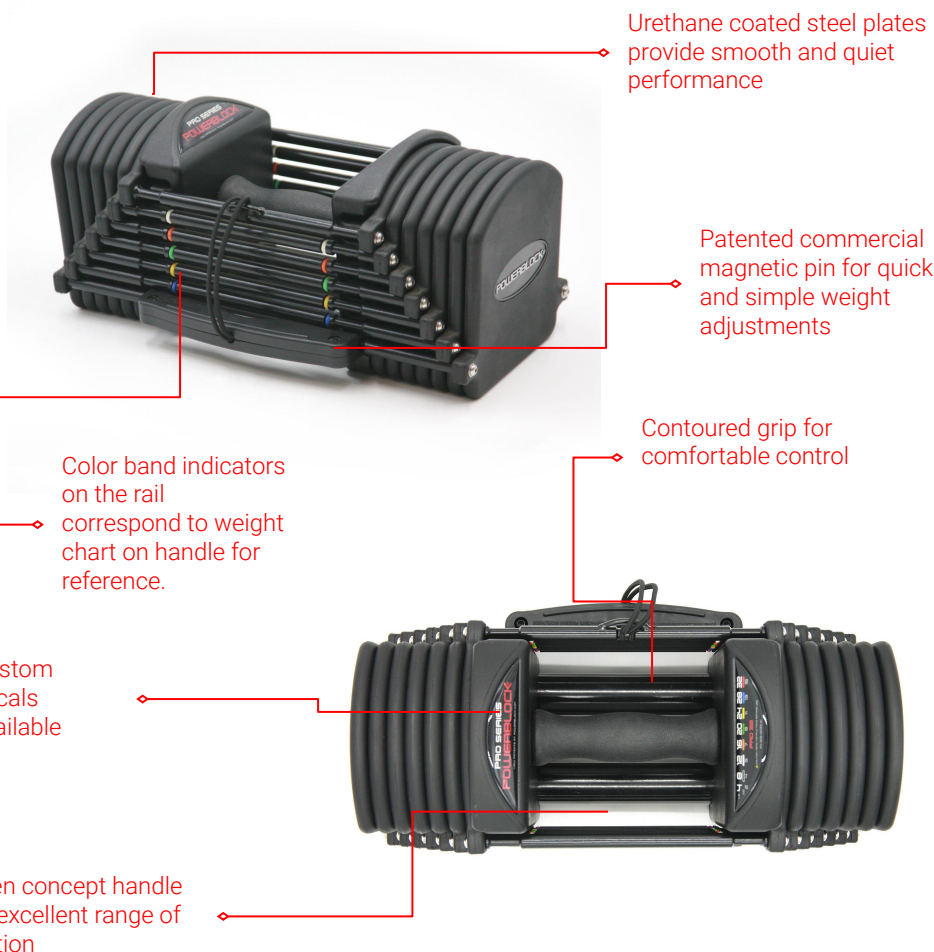

	Commercial Pro 32
UPC	181381000800
PN	505-00120-01
Weight Range	4 - 32 lbs 1.8kg - 14.5kg
Replaces Dumbbells	4, 8, 12, 16, 20, 24, 28, 32
Increments	4 lbs 1.1 kg
Dimensions	12" L x 5.75" W x 5.5" H
Grip Diameter	1.25" (32 mm) Contoured
Grip Length	4.88" (12.39 cm)
Grip Material	TPR
Weight Plates	Polyurethane coated steel
Pin	Magnetic polypropylene pin, rated for 500 lbs.
Warranty	1 Year Limited Commercial Warranty
Shipping	Sold in Pairs. Ships in multiple boxes. Stand sold separately

P: 403.265.1377
W: btbfitness.ca



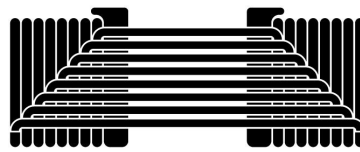

POWERBLOCK

WORLD'S BEST DUMBBELL

PRO Commercial

Commercial Pro 50

In 1993 PowerBlock introduced the world's first quick-change adjustable dumbbell. Today we remain the only adjustable dumbbell found in the training facilities of pro sports teams, major colleges and universities and elite training facilities around the world.

Compact Just 12.5" in Length at 50 lbs

Convenient Replaces up to 9 pairs of traditional dumbbells

Quick and Easy Adjustability Ideal for supersets and pyramid loading

Convertible Compatible with Pro Kettlebell Handle

Trusted by professional & elite athletes and their trainers

Proven performance and reliability

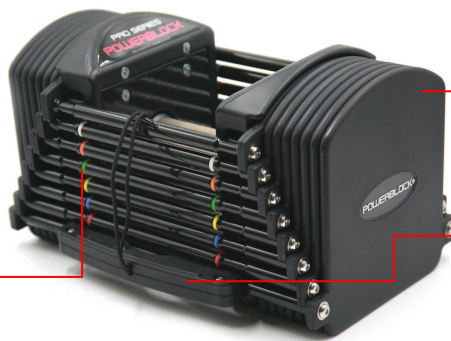

Urethane coated steel plates provide smooth and quiet performance

Patented commercial magnetic pin for quick and simple weight adjustments

Color band indicators on the rail correspond to weight chart on handle for reference.

Knurled Steel Grip provides great control

Custom decals available



Open concept handle for excellent range of motion

	Commercial Pro 50
UPC	181381000732
PN	505-00121-01
Weight Range	10 - 50 lbs 2.2 - 22.7 kg
Replaces Dumbbells	10, 15, 20, 25, 30, 35, 40, 45, 50
Increments	5 lbs 2.2 kg
Dimensions	12.5" L x 7" W x 7.25" H
Grip Diameter	1.3" (33 mm) Straight
Grip Length	4.88" (12.39 cm)
Grip Material	Knurled Steel Hard Chromed
Weight Plates	Polyurethane coated steel
Pin	Magnetic polypropylene pin, rated for 500 lbs.
Warranty	1 Year Limited Commercial Warranty
Shipping	Sold in Pairs. Stand included with price. Ships in multiple boxes

P: 403.265.1377
W: btbfitness.ca



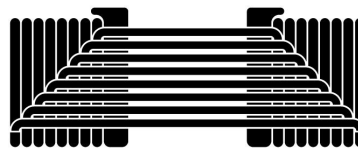

POWERBLOCK

WORLD'S BEST DUMBBELL

PRO Commercial

Commercial Pro 90

In 1993 PowerBlock introduced the world's first quick-change adjustable dumbbell. Today we remain the only adjustable dumbbell found in the training facilities of pro sports teams, major colleges and universities and elite training facilities around the world.

Compact Just 17" in Length at 90lbs

Convenient Replaces up to 18 pairs of traditional dumbbells

Quick and Easy Adjustability Ideal for supersets and pyramid loading

Convertible Compatible with Pro Kettlebell Handle

Trusted by professional & elite athletes and their trainers

Proven performance and reliability

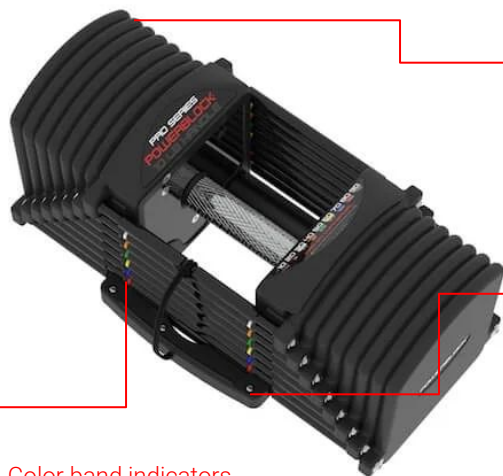

Urethane coated steel plates provide smooth and quiet performance

Patented commercial magnetic pin for quick and simple weight adjustments

Knurled Steel Grip provides great control

Color band indicators on the rail correspond to weight chart on handle for reference.

Custom decals available

Open concept handle for excellent range of motion



	Commercial Pro 90
UPC	181381000855
PN	505-00122-01
Weight Range	5 - 90 lbs 2.2 - 40.8 kg
Replaces Dumbbells	5, 10, 15, 20, 25, 30, 35, 40, 45, 50, 55, 60, 65, 70, 75, 80, 85, 90
Increments	5 lbs 2.2 kg
Dimensions	17" x 7" x 7.25"
Grip Diameter	1.3" (33 mm) Straight
Grip Length	4.88" (12.39 cm)
Grip Material	Knurled Steel Hard Chromed
Weight Plates	Polyurethane coated steel
Pin	Magnetic polypropylene pin, rated for 500 lbs.
Warranty	1 Year Limited Commercial Warranty
Shipping	Sold in Pairs. Stand included with price. Ships in multiple boxes

P: 403.265.1377
W: btbfitness.ca



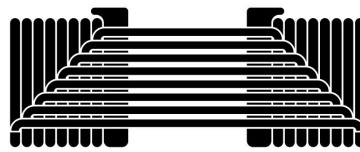

POWERBLOCK

WORLD'S BEST DUMBBELL

PRO Commercial

Commercial Pro 125

In 1993 PowerBlock introduced the world's first quick-change adjustable dumbbell. Today we remain the only adjustable dumbbell found in the training facilities of pro sports teams, major colleges and universities and elite training facilities around the world.

Compact Just 17" in Length at 125 lbs

Convenient Replaces up to 16 pairs of traditional dumbbells

Quick and Easy Adjustability Ideal for supersets and pyramid loading

Trusted by professional & elite athletes and their trainers

Proven performance and reliability

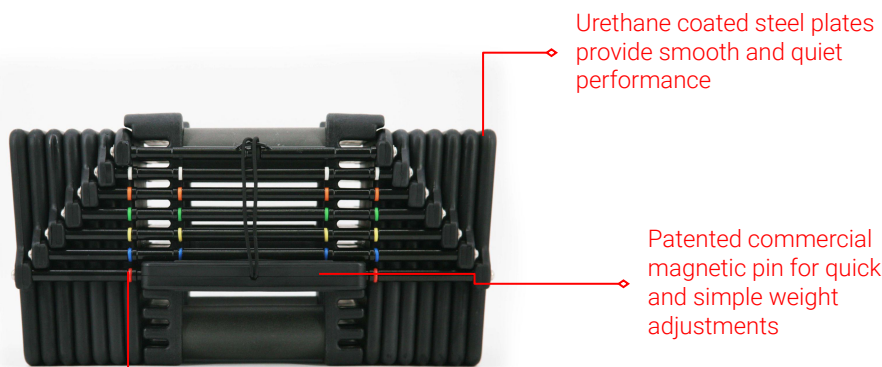

Color band indicators on the rail correspond to weight chart on handle for reference.

Contoured grip for comfortable control



	Commercial Pro 125
UPC	181381000817
PN	505-00123-01
Weight Range	12.5 - 125 lbs 5.7kg - 56.7 kg
Replaces Dumbbells	12.5, 20, 27.5, 35, 42.5, 50, 57.5, 65, 72.5, 80, 87.5, 95, 102.5, 110, 120, 125
Increments	7.5 - 10 lbs 3.4 kg - 4.5 kg
Dimensions	17" x 8.5" x 9"
Grip Diameter	1.49" (38 mm) Contoured
Grip Length	4.88" (12.39 cm)
Grip Material	TPR
Weight Plates	Polyurethane coated steel
Pin	Magnetic polypropylene pin, rated for 500 lbs.
Warranty	1 Year Limited Commercial Warranty
Shipping	Sold in Pairs. Stand included with price. Ships in multiple boxes
Stand	Stand Included

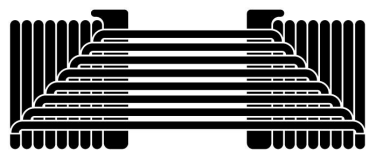

POWERBLOCK

WORLD'S BEST DUMBBELL

PRO Commercial

Commercial Pro 175

In 1993 PowerBlock introduced the world's first quick-change adjustable dumbbell. Today we remain the only adjustable dumbbell found in the training facilities of pro sports teams, major colleges and universities and elite training facilities around the world.

Compact Just 19" in Length at 175 lbs

Convenient Replaces up to 22 pairs of traditional dumbbells

Quick and Easy Adjustability Ideal for supersets and pyramid loading

Trusted by professional & elite athletes and their trainers

Proven performance and reliability

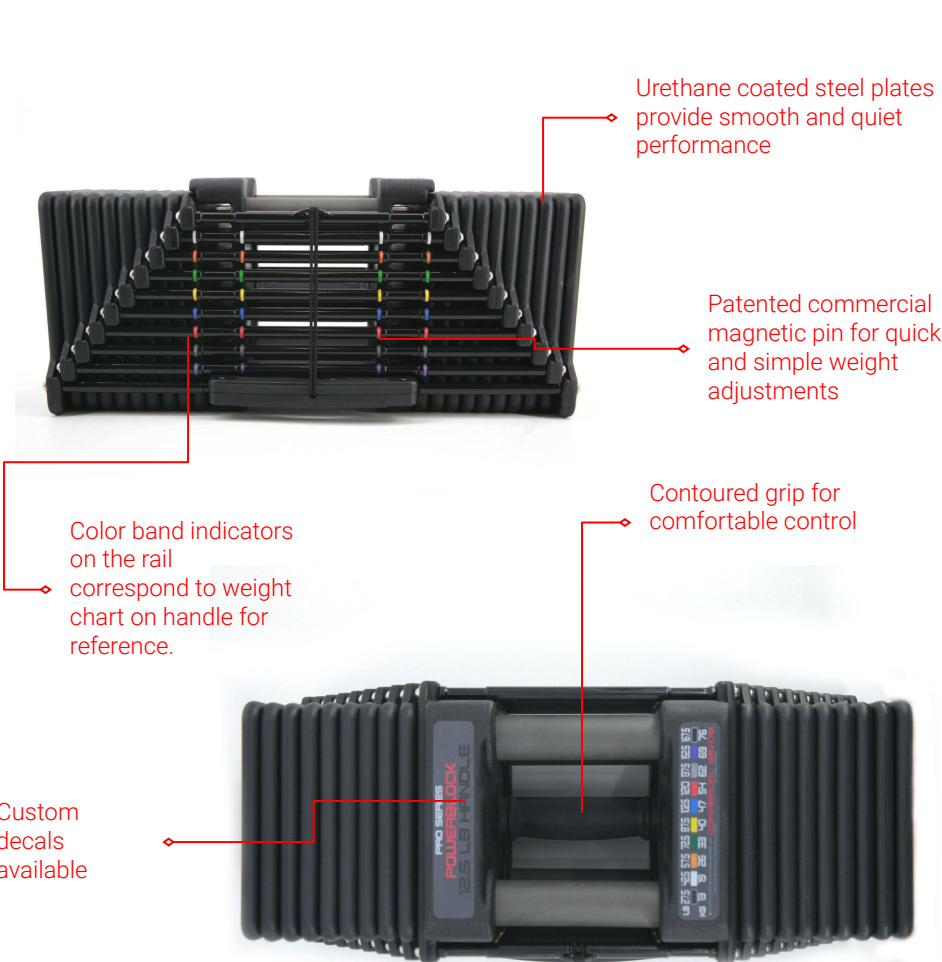

	Commercial Pro 175
UPC	181381000817
PN	505-00123-01
Weight Range	12.5 - 175 lbs 5.7kg - 79.4 kg
Replaces Dumbbells	12.5, 20, 27.5, 35, 42.5, 50, 57.5, 65, 72.5, 80, 87.5, 95, 102.5, 110, 120, 125, 137.5, 145, 152.5, 160, 167.5, 175
Increments	7.5 - 10 lbs 3.4 kg - 4.5 kg
Dimensions	19" x 8.5" x 9" (19" x 8.5" x 9" w/add on kit)
Grip Diameter	1.49" (38 mm) Contoured
Grip Length	4.88" (12.39 cm)
Grip Material	TPR
Weight Plates	Polyurethane coated steel
Pin	Magnetic polypropylene pin, rated for 500 lbs.
Warranty	1 Year Limited Commercial Warranty
Shipping	Sold in Pairs. Stand included with price. Ships in multiple boxes
Stand	Stand Included

P: 403.265.1377
W: btbfittness.ca



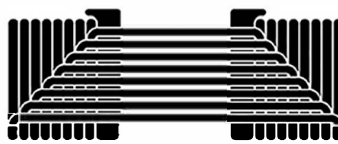

POWERBLOCK

WORLD'S BEST DUMBBELL

Pro Commercial Stands

Pro Rack Stand

Pro Max Stand

In 1993 PowerBlock introduced the world's first quick-change adjustable dumbbell. Today we remain the only adjustable dumbbell found in the training facilities of pro sports teams, major colleges and universities and elite training facilities around the world.

Tray features storage for second set of handles



Lower tray for additional storage

Durable powder coat finish keeps the stand looking new in high traffic environments

	Pro Rack Stand	Pro Max Stand
UPC	181381000879	181381000824
PN	600-00147-01	600-00148-03
Price	Stand is included with set	Stand is included with Set
Works with these PowerBlock Models	Commercial Pro 50 Commercial Pro 90	All models
Dimensions	19" W, 21" L, 28" H	25" W, 21" L, 26" H
Construction	Powder Coated 14 GA. Steel	Powder Coated 14 GA. Steel
Warranty	1 Year Limited Commercial Warranty	

Optional Pro Max Stand with wheels



Angled tray top for easier access to the set

Open design allows for placing the feet closer to the weights for safer lifting

Lower tray for additional storage

Locking wheels

P: 403.265.1377
W: btbfitness.ca

